





Radioport: A Radio Network for
Monitoring and Diagnosing
Computer Systems

Hans Eberle

Sun Microsystems Laboratories



Proliferation of Wireless Technologies

- Wireless networks
 - 802.11
 - Bluetooth
 - RFID
- Motivation
 - Mobility
 - Ease-of-use
 - Cost
 - Connectivity

Hot Interconnects 10

2

Wires vs. Radio

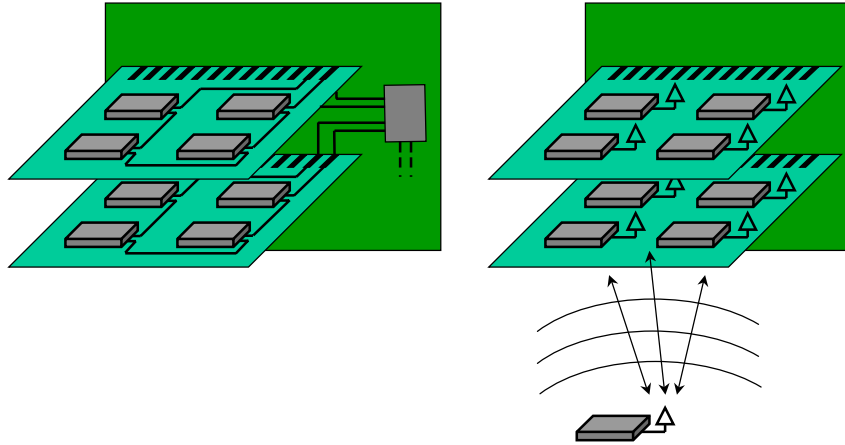

Hot Interconnects 10

3

Radioport Technology

- Radio network for computer systems
- Orthogonal to physical interconnect
- Out-of-band signaling
 - Monitoring
 - Diagnosing
- Integration levels
 - Chips
 - Boards
 - Modules

Hot Interconnects 10

4

Advantages

- **Reliable**
 - No indirections as found in daisy-chained or hierarchical interconnects
 - Overcomes limitations of redundancy
 - No dependence on system interconnect
 - No wear and tear
- **Non-intrusive**
- **Cost-effective thanks to lacking physical interconnect**
 - Fewer wires, connectors, pins
 - Higher packaging density

Wired Dependencies

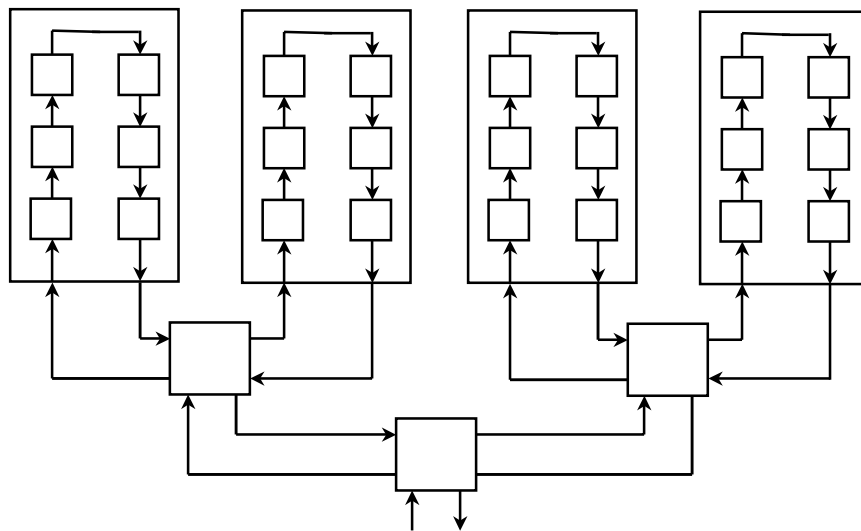

Wired Dependencies

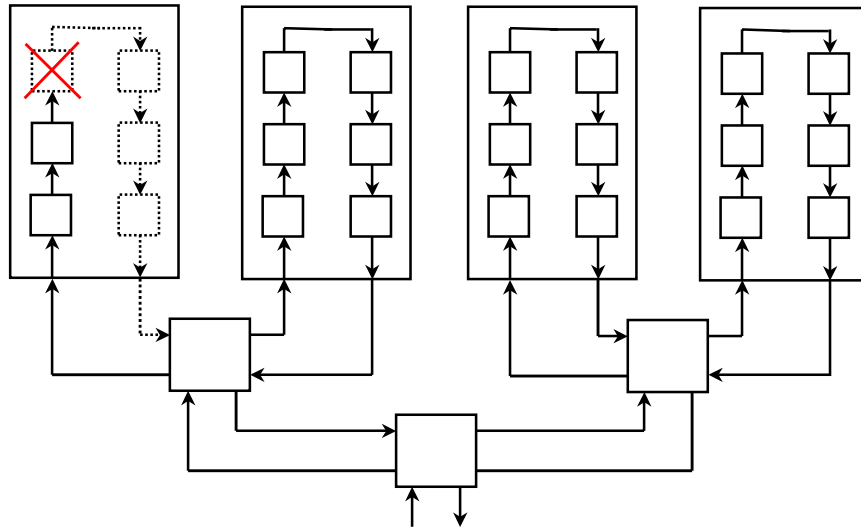

Hot Interconnects 10

7

Wired Dependencies

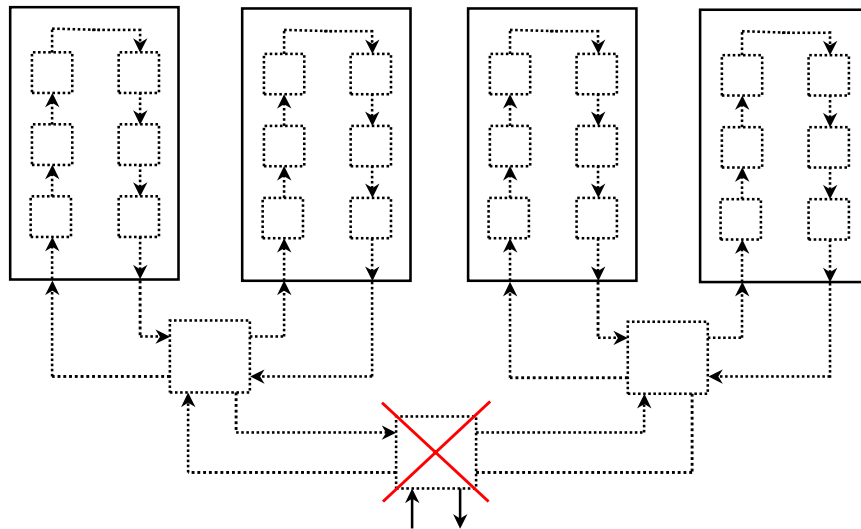

Hot Interconnects 10

8

Applications

- Application areas
 - Identification
 - Configuration
 - Monitoring
 - Diagnostics
- Application examples
 - Wireless sensors
 - Wireless JTAG
 - System configuration
 - Tricoder for field service

Application: Wireless Sensors

- Monitor voltage and temperature of system components
- Improved robustness: no dependencies on system hardware/software
- Cost-efficient thanks to lack of physical interconnect
- Temporary deployment of self-powered sensors for thermal analysis

Application: Wireless JTAG

- Replace 5-wire JTAG port with Radioport
- Applications
 - Testing
 - Configuring
- Improved robustness: broadcast medium replaces daisy-chained/hierarchical wiring
- Non-intrusiveness simplifies testing and configuring

Application: System Configuration

- Track and check system configuration down to chip-level granularity
 - Component specifications
 - Vendor information
 - Logged information
- Configuration management
 - Manufacturing floor
 - Field service

Application: Field Service

- Diagnose systems wirelessly
 - Component information
 - Component history
 - Error log
- No dependence on working system
- Non-intrusive

Implementation Choices

- Integration levels
 - On-chip
 - Off-chip
 - Antenna design
- Power supply
 - Battery
 - Electromagnetic field

Prototype: Radioport for DIMMs

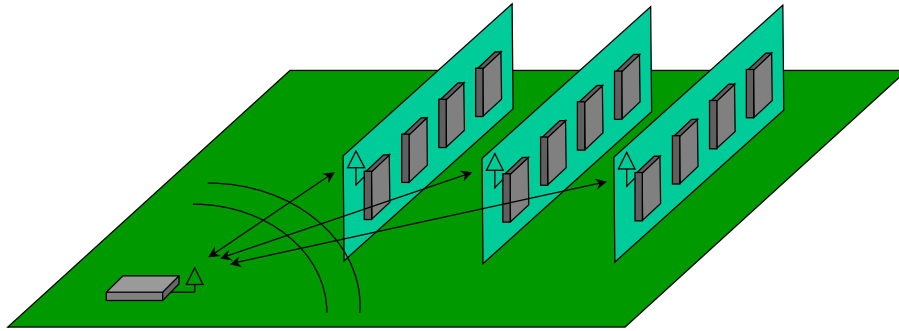

Prototype: Organization

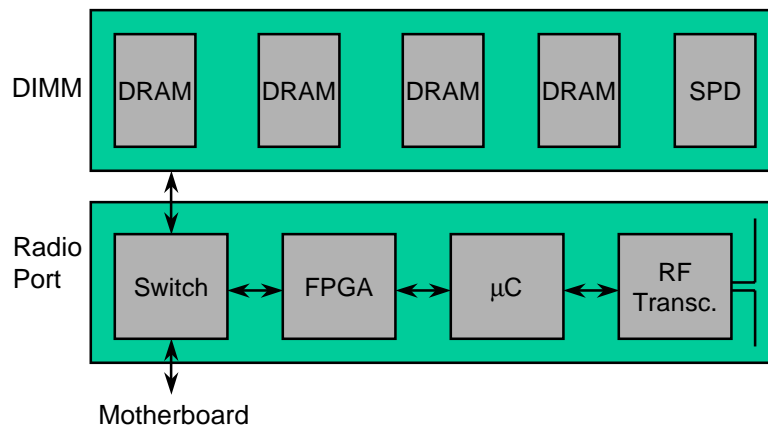

Prototype: Link Protocol

- OOK modulation, 916.5 MHz carrier, 19.2 kBaud data rate
- Functions
 - Voltage, temperature
 - Serial presence detect (SPD)
 - Memory self-test
 - Boundary-scan
- Packet format

2	1	0.5	0.5	1	1	1..17	1
0101..	Start	Dst	Src	Seq	Len	Msg	CRC

Prototype: DIMM Extender Card

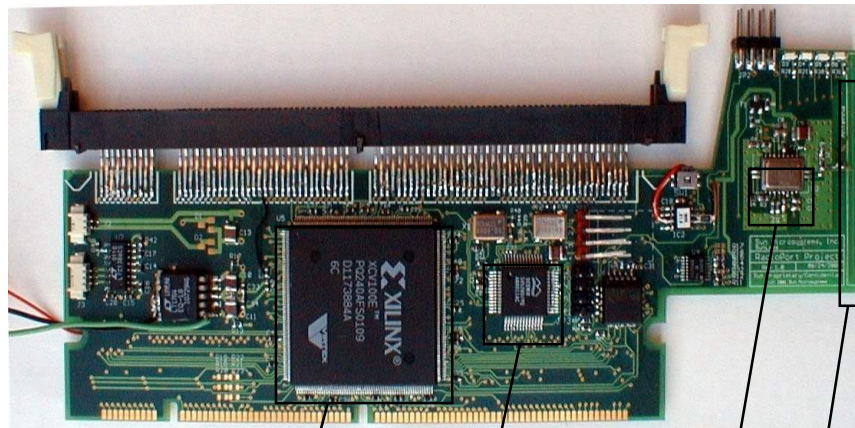

FPGA

µC

Radio Transceiver

Antenna

Future Work

- Integration
- Cost reduction
- Signal interference/integrity
- Security
- Multi-master protocols
- Multi-hop networks

Summary

- Radioport offers attractive alternative for out-of-band signaling
 - System configuration
 - Monitoring
 - Diagnostics
- Advantages
 - Higher reliability
 - Improved ease-of-use
 - Lower implementation cost