

# The Alpha 21364 Network Architecture

David Webb, Peter Bannon, Steven Lang,  
Shubhendu Mukherjee, Aaron Spink

## Outline

- Overview of 21364
- The Router
  - Organization
  - Virtual channels
  - Routing
  - Pipeline and Arbitration
  - Load Balancing Rules
- Conclusion

## Alpha 21364 Overview

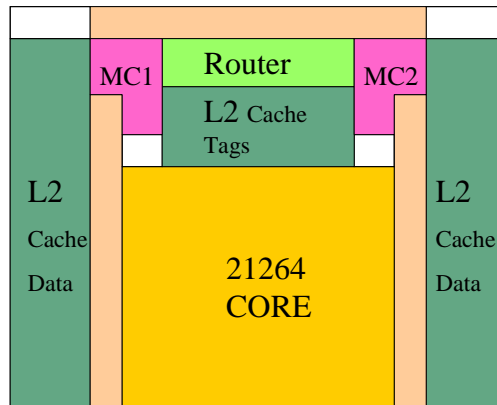

## Alpha 21364 Stats

- 152 million transistors
- 0.18um bulk CMOS
- 1.2 GHz
- 1.75 megabyte L2 cache
- 12.8 gigabytes/sec local memory bandwidth
- 22.4 gigabytes/sec total router bandwidth

### System Overview

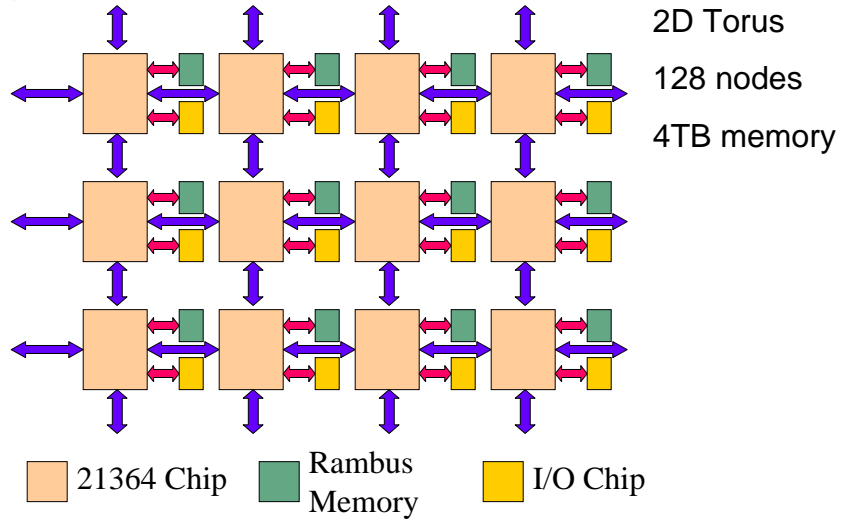

### Router Logical View

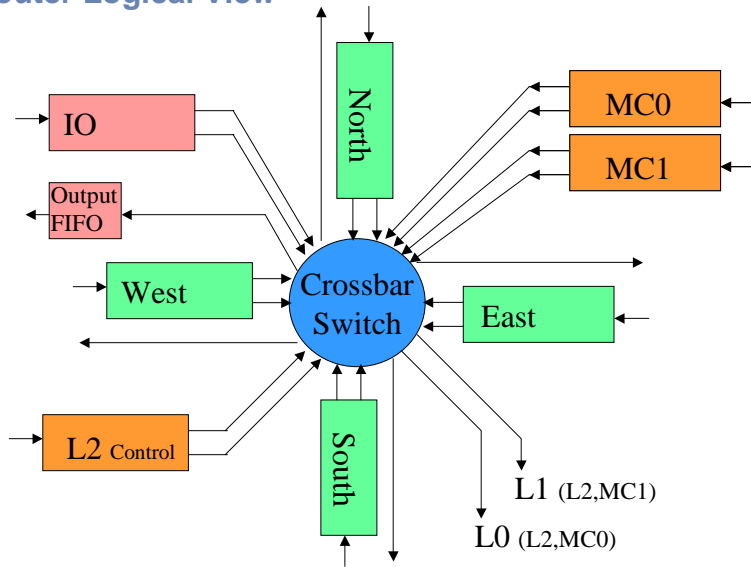

## Router Stats

- 2.2M transistors
- 410 I/O pins + 256 “pins” to local resources
- Input buffering, ~250 packets,
- Pin-to-pin latency 10.8ns at 1.2GHz
- 4 Compass Points
  - 32b+7ecc, clock forwarded, 3.2Gb/sec at 800MHz signaling rate
- IO
  - 32b+7ecc, clock forwarded, 1.6Gb/sec at 400MHz signaling rate

## Deadlock Free Virtual Channels

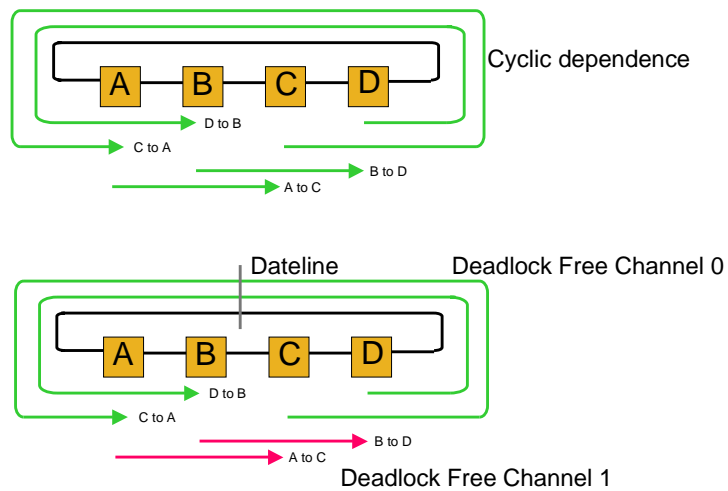

**Packet Classes X Routing Channels = 19 Virtual Channels**

- Request
- Forward
- Block Response
- Non-Block Response
- Write IO
- Read IO
- Special (point-to-point, only 1 channel)
- Deadlock Free 0
- Deadlock Free 1
- Adaptive

**Deadlock Free Routing**

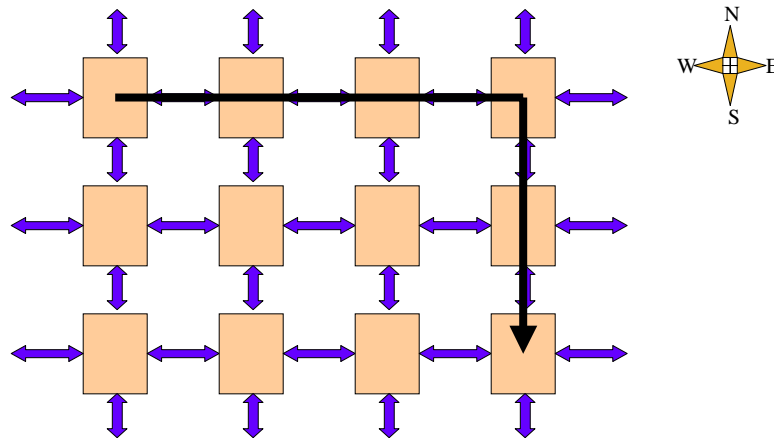

### Adaptive Routing

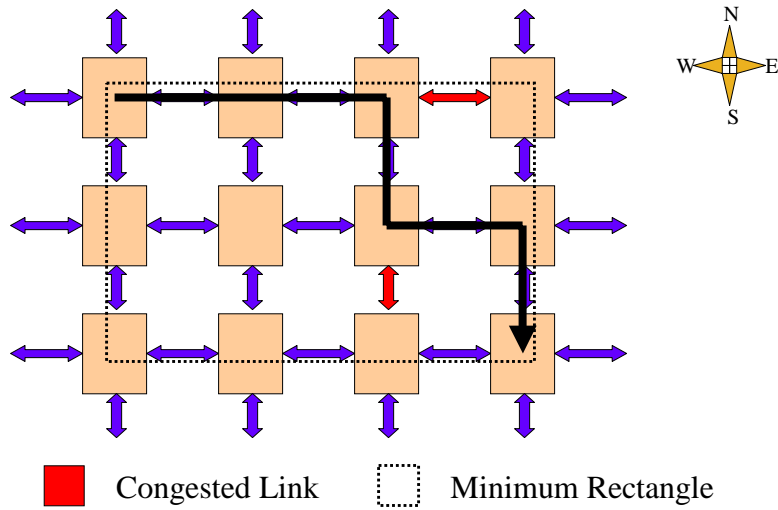

### Router Pipeline (Compass Point)

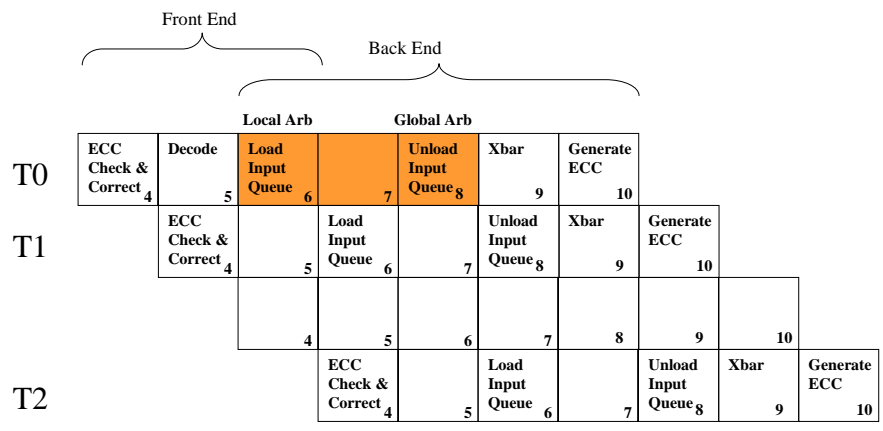

## Router Pipeline (Local Port)

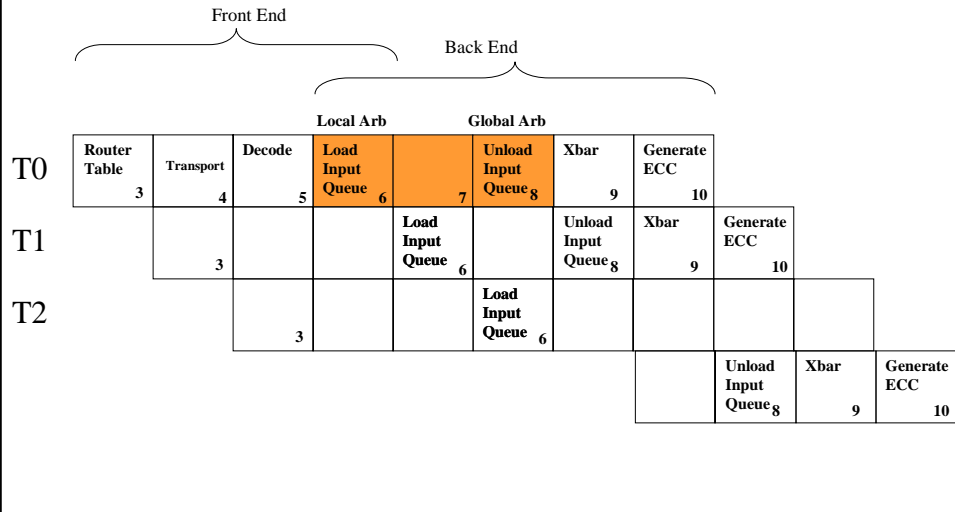

## Router Pipeline (IO Port)

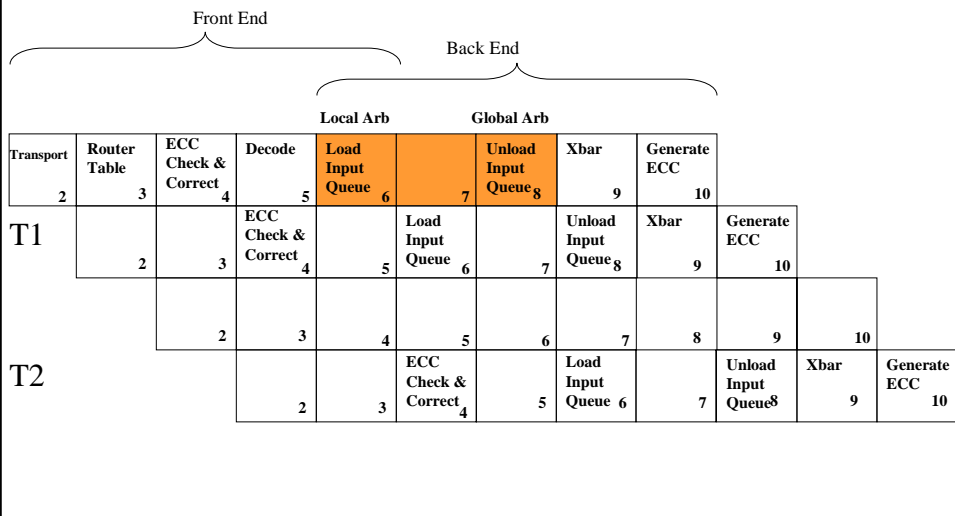

**COMPAQ**

### Local Arb

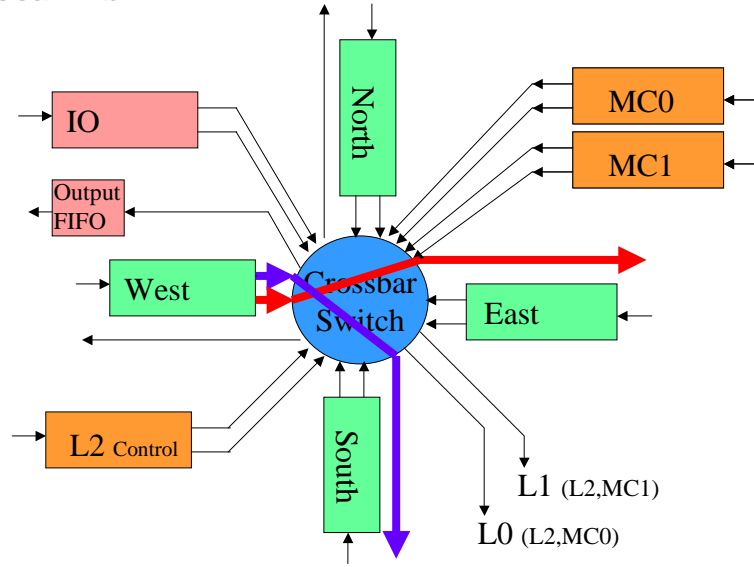

**COMPAQ**

### Arb Transport

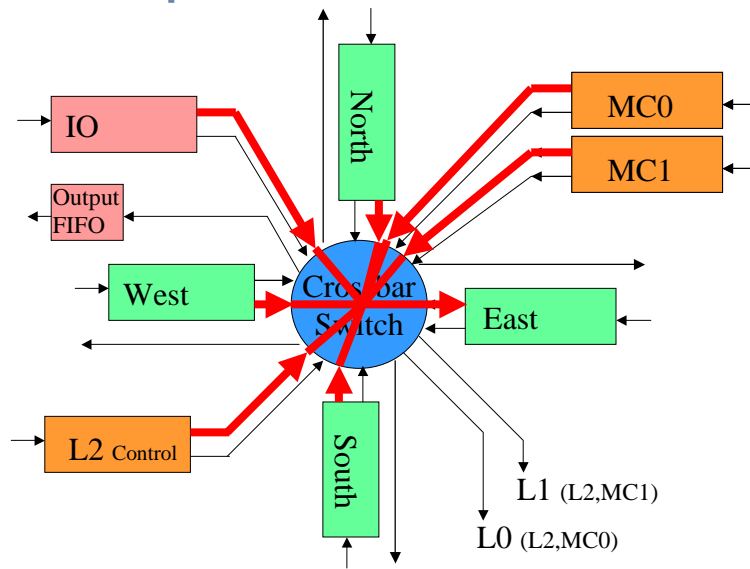

### Global Arb

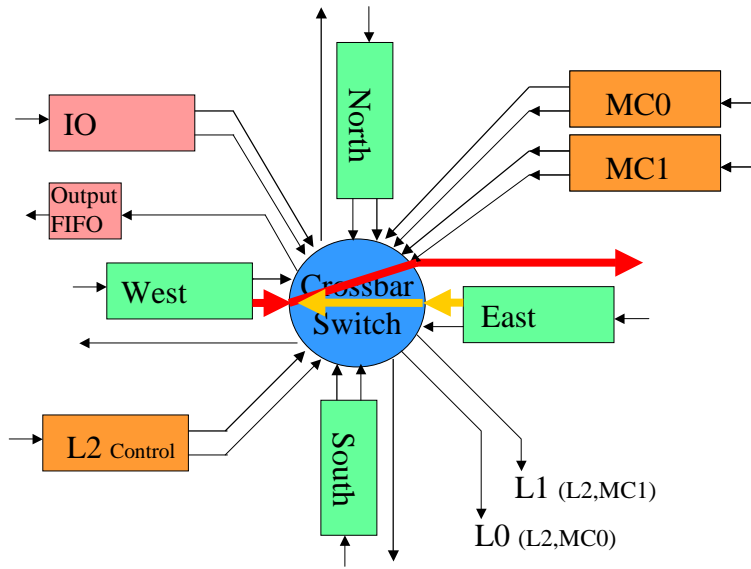

### Rotary Rule (Traffic Circle)

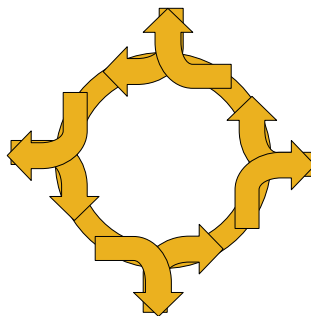

Incoming traffic yields to the traffic already in the circle.

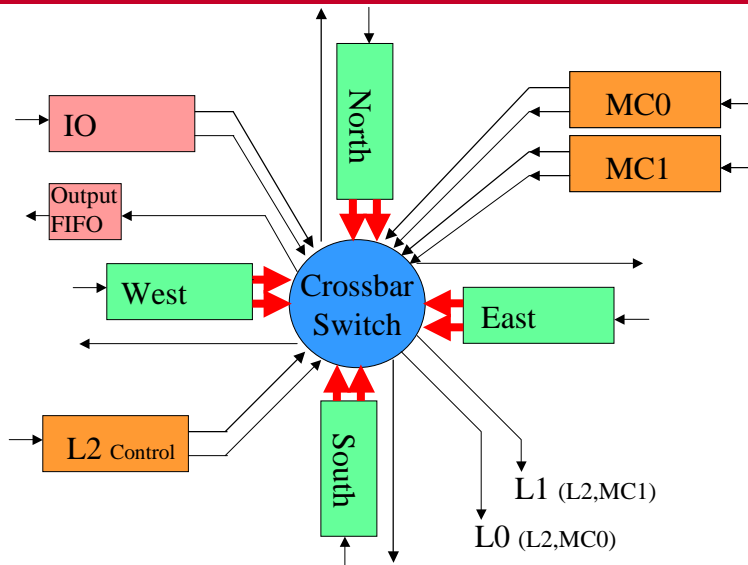

Packets from compass points are given priority over packets from the local ports, that represent new packets entering the network.

### Coherence Dependence Priority

L2 Controller Port

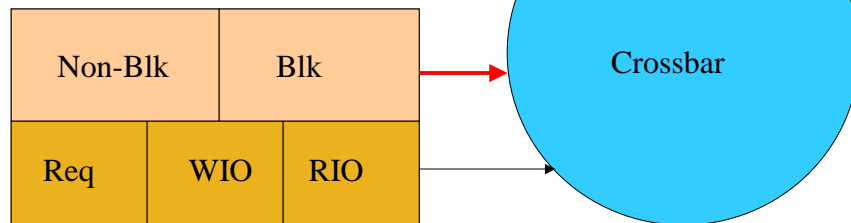

Give higher priority to Response packets, which complete Protocol transactions, over packet types that initiate new Protocol transactions.

## Conclusion

- Integrating a multiprocessor network interface on the processor die has many advantages
  - Leverages processor technology
    - Custom design style
    - Clock frequency
    - Process improvements
    - High pin count
    - Robust connection to local resources
  - Lowers system component count