

Optimized Routing for Large-Scale InfiniBand Networks

Torsten Hoefler, Timo Schneider,
and Andrew Lumsdaine

Open Systems Lab
Indiana University



Effect of Network Congestion

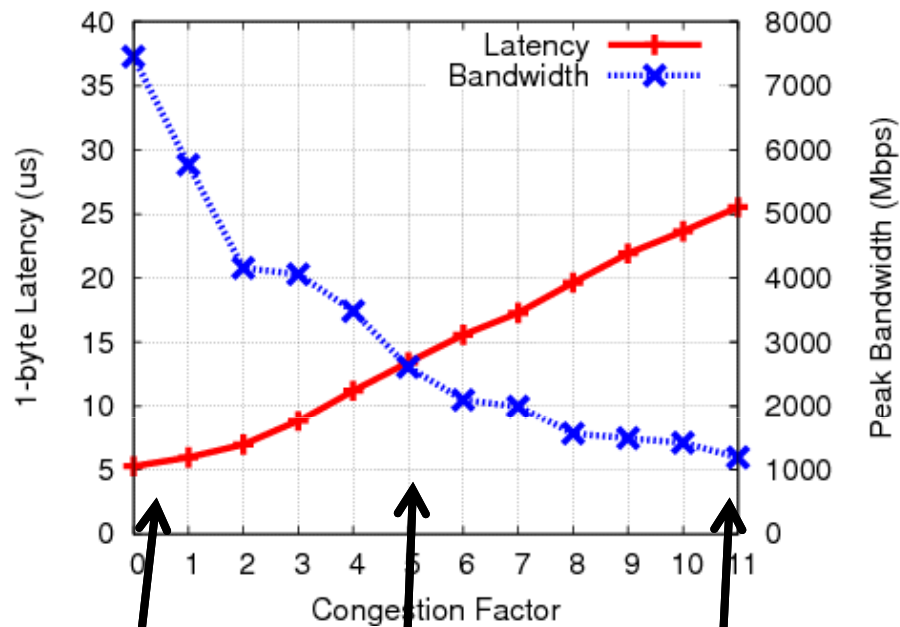

Microbenchmarks
(NetPIPE, IMB ping pong
Netgauge one_one)

Lower Bound!

Reality?

CHiC Supercomputer:

- 566 nodes, full bisection IB fat-tree
- effective Bisection Bandwidth: 0.699

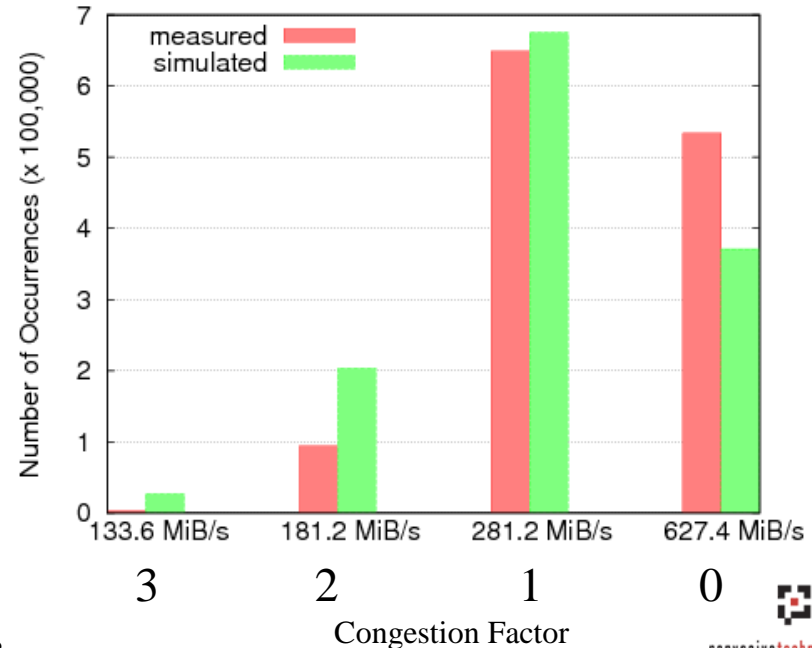

Full Bisection Bandwidth \neq Full Bandwidth

- expensive topologies do not guarantee high bandwidth
- deterministic oblivious routing cannot reach full bandwidth!
 - see Valiant's lower bound
 - random routing is asymptotically optimal but loses locality

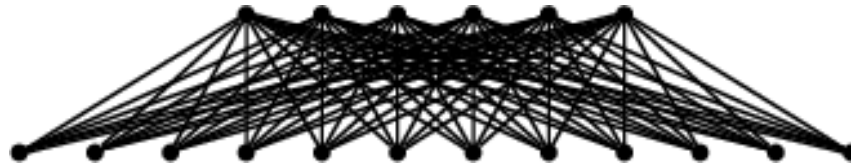

- but deterministic routing has many advantages
 - completely distributed
 - very simple implementation
- InfiniBand routing:
 - deterministic oblivious, destination-based
 - linear forwarding table (LFT) at each switch
 - lid mask control (LMC) enables multiple addresses per port



InfiniBand Routing Continued

- offline route computation (OpenSM)
- different routing algorithms:
 - MINHOP (finds minimal paths, balances number of routes local at each switch)
 - UPDN (uses Up*/Down* turn-control, limits choice but routes contain no credit loops)
 - FTREE (fat-tree optimized routing, no credit loops)
 - DOR (dimension order routing for k-ary n-cubes, might generate credit loops)
 - LASH (uses DOR and breaks credit-loops with virtual lanes)



Why do Credits Loop?

- IB uses credit-based p2p flow-control
 - egress messages sent only if receive-buffer available

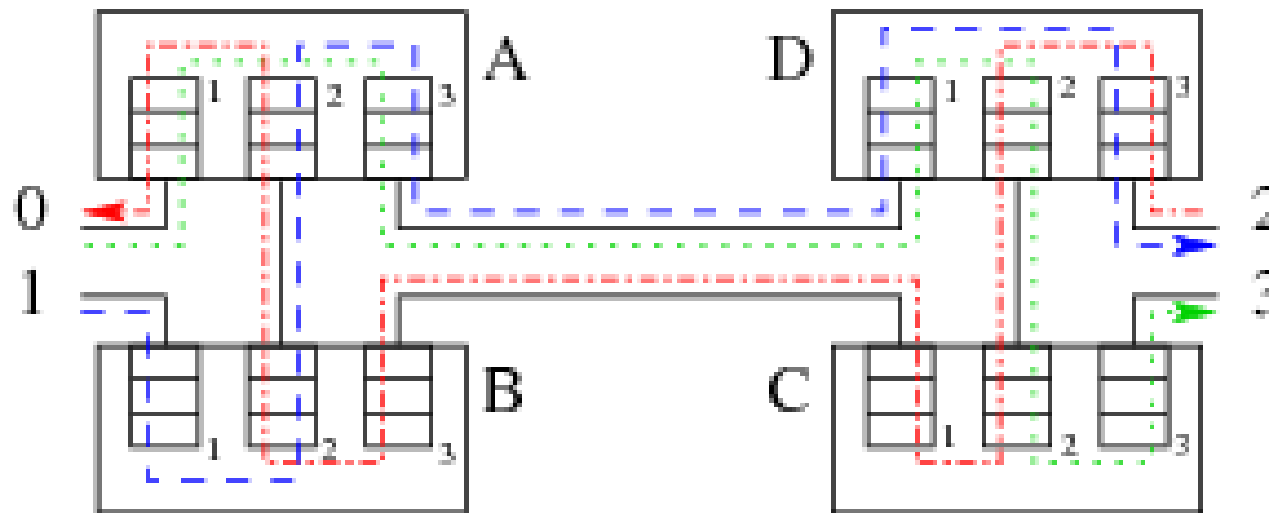

- very similar to deadlocks in wormhole-routed systems



How to deal with Credit Loops?

- prevent (UP*/Down*, turn-based routing)
- resolve (LASH, use VLS to break cycles)
- ignore (MINHOP, DOR, not as bad as it sounds, might deadlock but can be “resolved” with packet timeouts
 - discouraged by IB spec



Some Theoretical Background

- model network as $G=(V_P \cup V_C, E)$
- path $r(u,v)$ is a path between $u,v \in V_P$
- routing R consists of $P(P-1)$ paths
- edge load $l(e)$ = number of paths on $e \in E$
- edge forwarding index $\pi(G,R)=\max_{e \in E} l(e)$
 - $\pi(G,R)$ is a trivial upper bound to congestion!

- goal is to find R that minimizes $\pi(G,R)$
 - shown to be NP-hard in the general case



Two heuristics based on SSSP

- we propose two heuristics:
 - P-SSSP
 - P²-SSSP
- P-SSSP starts a SSSP run at each node
 - finds paths with minimal edge-load $l(e)$
 - updates routing tables in reverse
 - essentially SDSP
 - updates $l(e)$ between runs
- let's discuss an example ...



P-SSSP Routing (1/3)

Step 1:
Source-node 0:

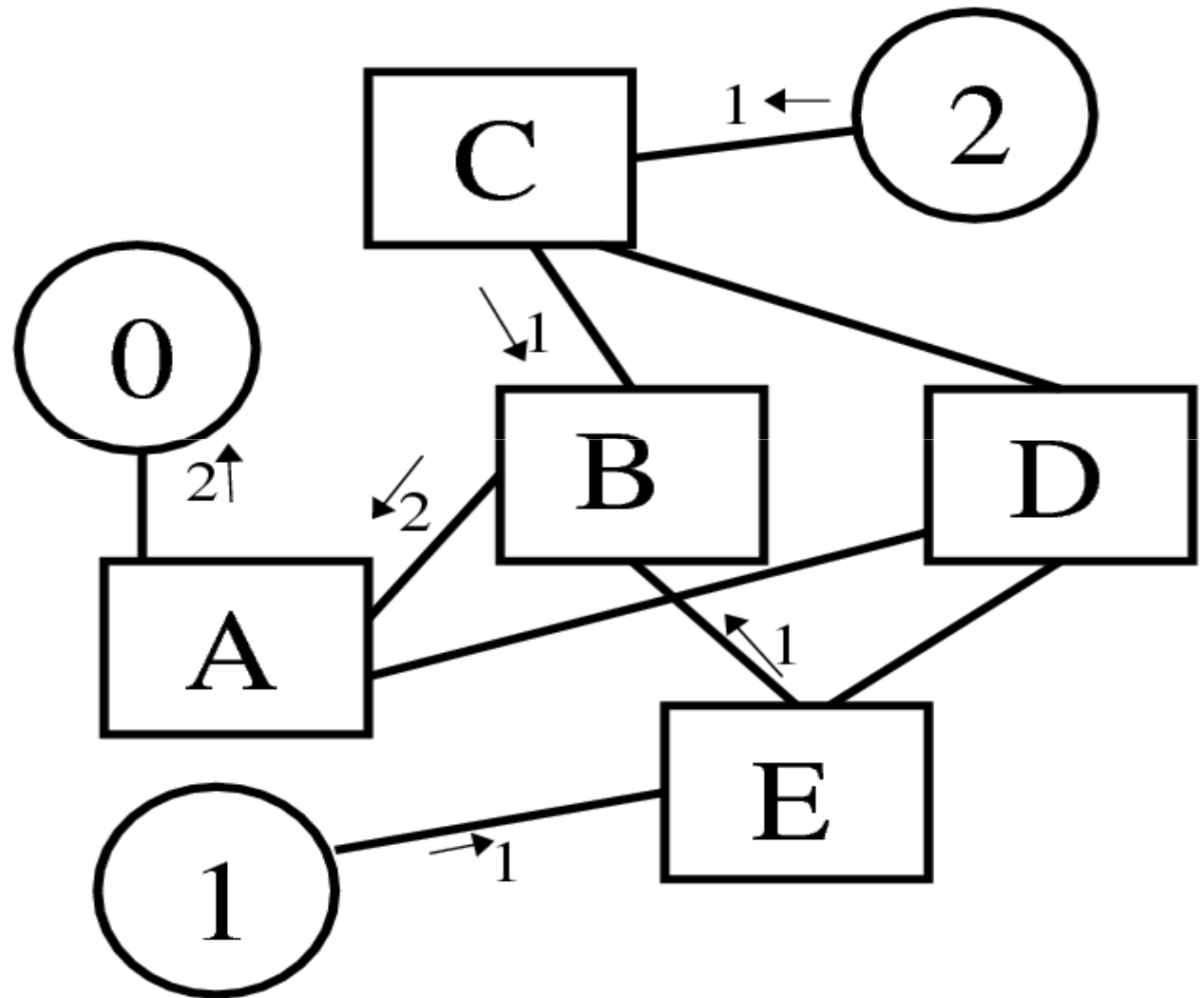

P-SSSP Routing (2/3)

Step 2:
Source-node 1:

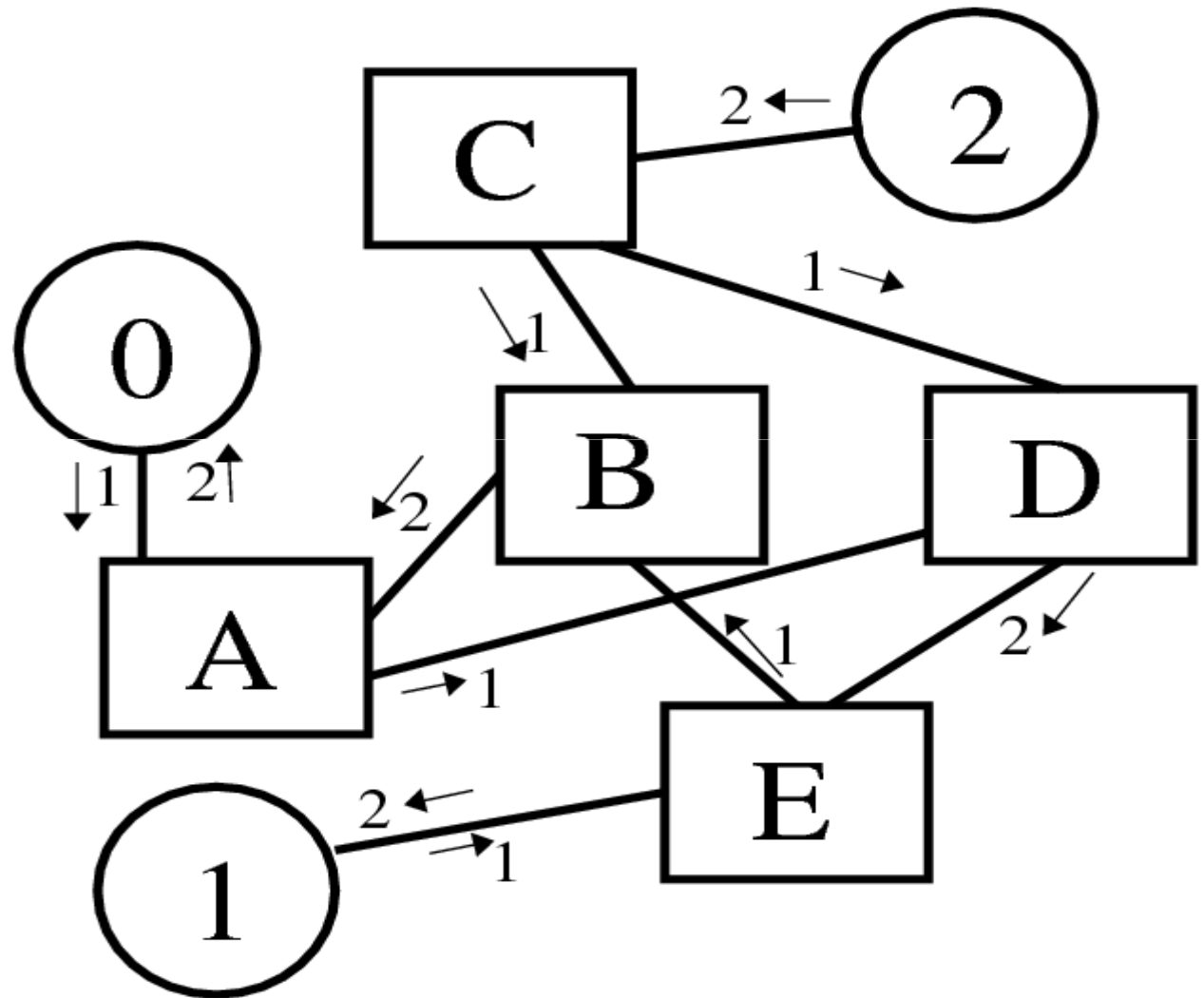

P-SSSP Routing (3/3)

Step 3:
Source-node 2:

$$\pi(G,R)=2$$

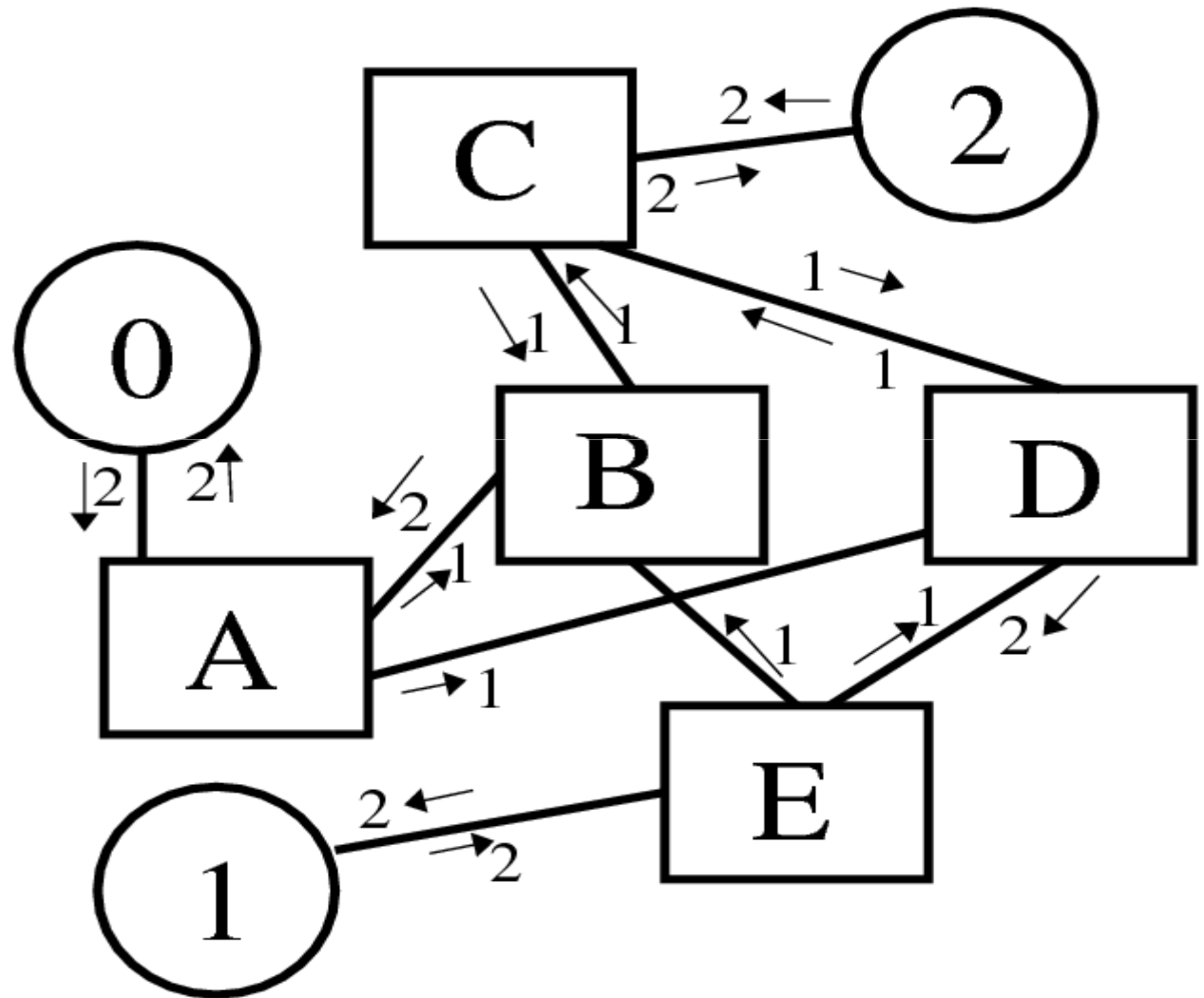

P²-SSSP

- simply run a single SSSP for each route
 - better (expensive) heuristic, lower $\pi(G,R)$

$$\pi(G,R)=1$$

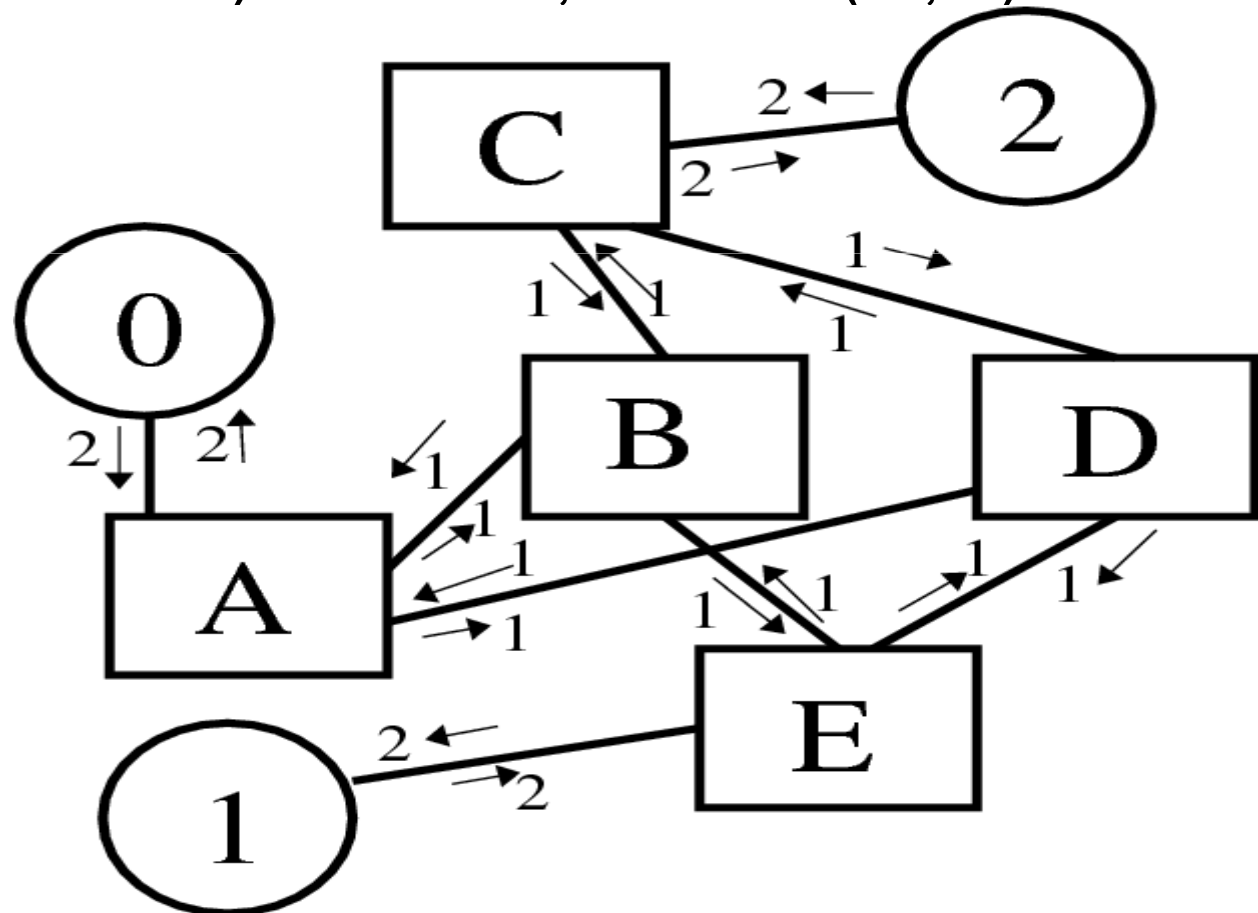

How to Assess a Routing?

- edge forwarding index is a trivial upper bound
- ability to route permutations is more important
 - bisect P into two equally-sized partitions
 - choose exactly one random partner for each node
 - $\Theta(P!/(P/2)!)$ combinations!
- our simulation approach:
 - pick N ($=5000$) random bisections/matchings
 - compute average bandwidth
 - shown to be rather precise (Cluster'08)



Comparison to Real Systems

- `ibdiagnet`, `ibnetdiscover`, and `ibsim`
- we extracted topology and routing from:
 - Thunderbird (SNL) – 4390 LIDs
 - thanks to: Adam Moody & Ira Weiny
 - Ranger (TACC) – 4080 LIDs
 - thanks to: Christopher Maestas
 - Atlas (LLNL) – 1142 LIDs
 - thanks to: Len Wisniewsky
 - Deimos (TUD) – 724 LIDs
 - thanks to: Guido Juckeland and Michael Kluge
 - Odin (IU) – 128 LIDs



Real-world Results

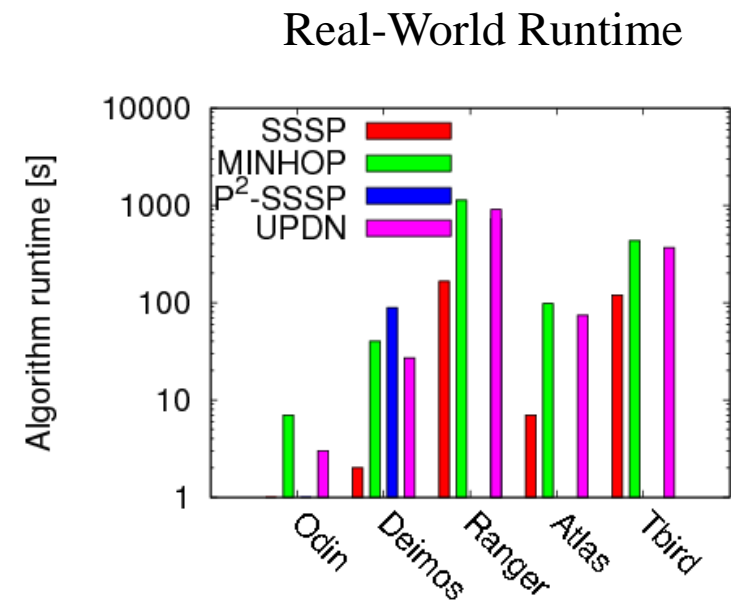
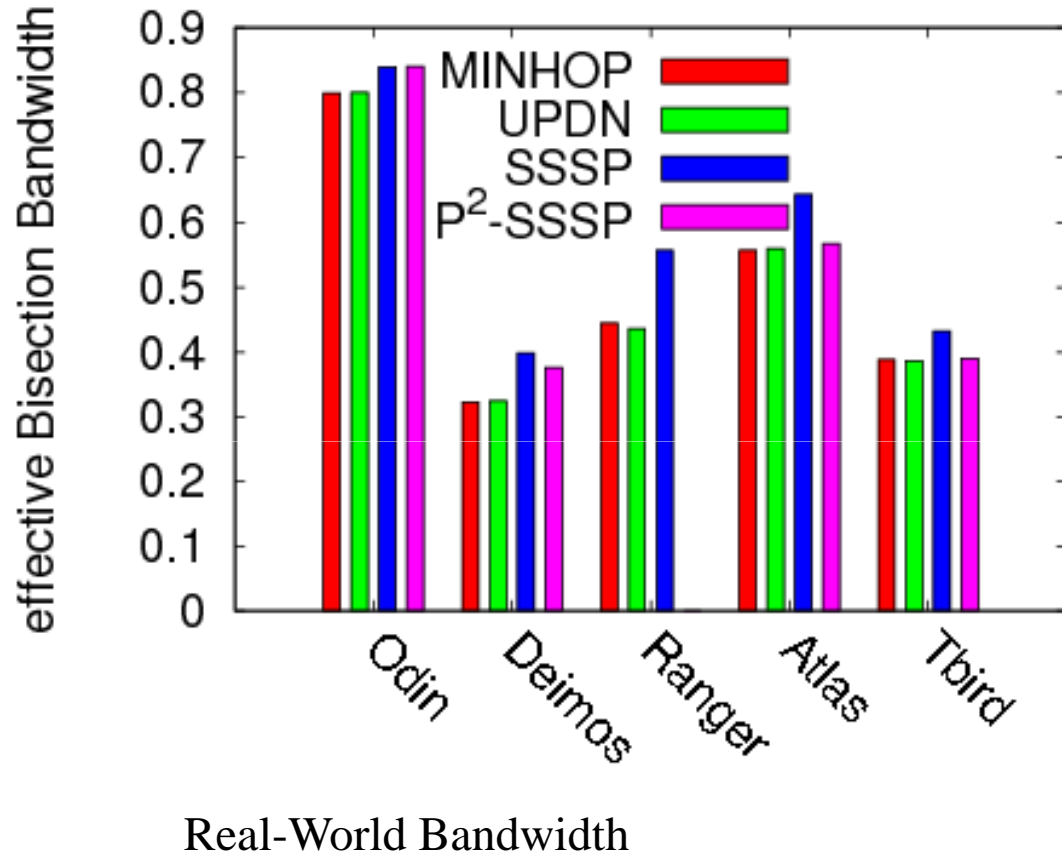

Some more Topologies

Fat-tree topologies

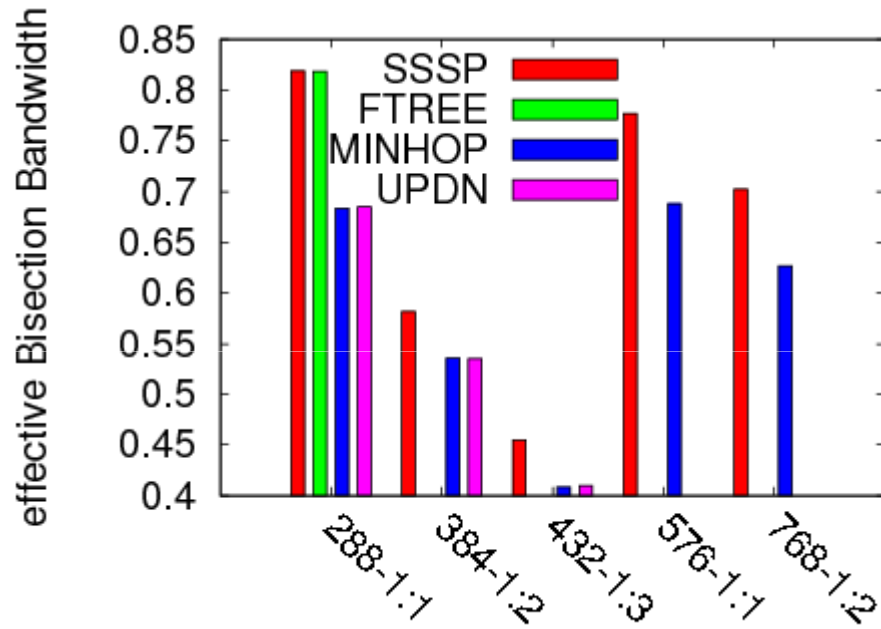

k-ary 2,3-cube topologies (torus)
(filled switches with endpoints)

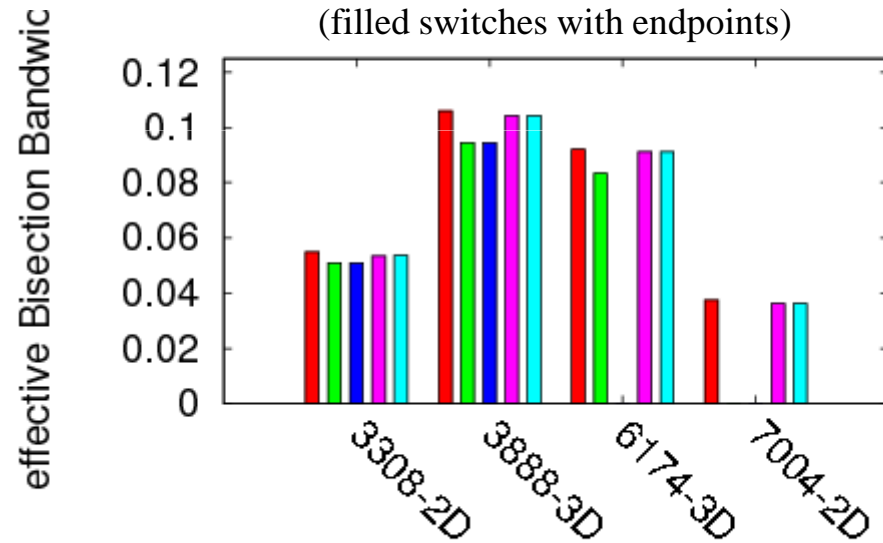

Even more Topologies

2-ary n-cube topologies (hypercube)
(filled switches with endpoints)

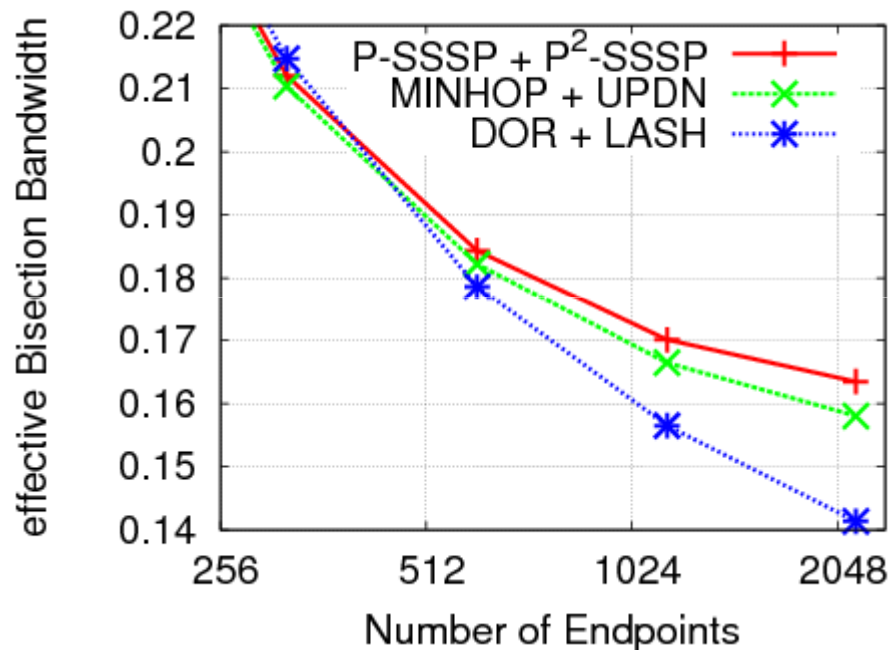

random topologies
(12 nodes per switch)

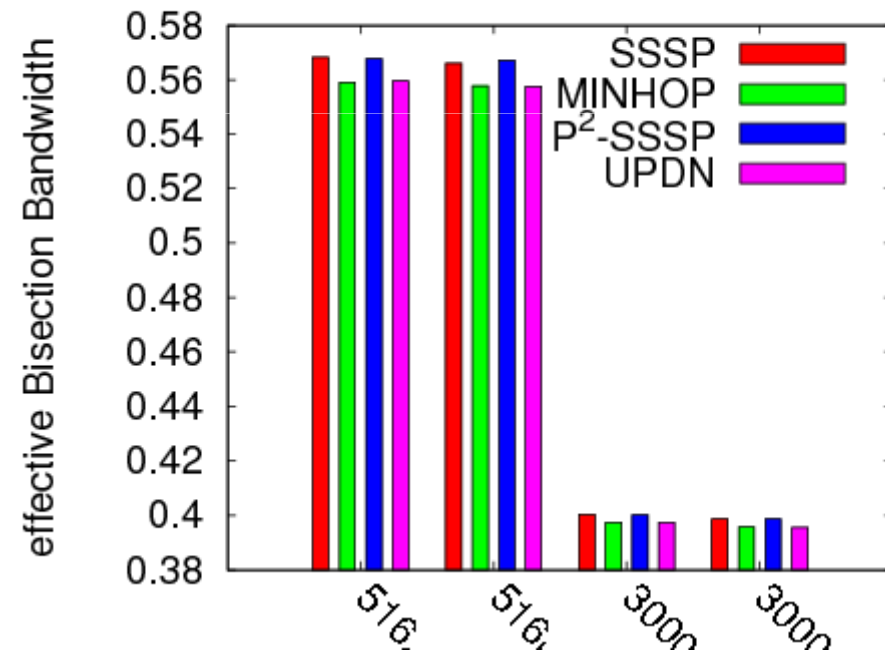

Simulations are good, but still Simulations

- we implemented our routing with OpenSM's file method
- tested it on the Deimos and Odin clusters (needs exclusive admin access to whole machine – many thanks to Guido Juckeland)
- Odin is standard fat-tree, Deimos' topology:



Benchmark Results Odin

Simulation

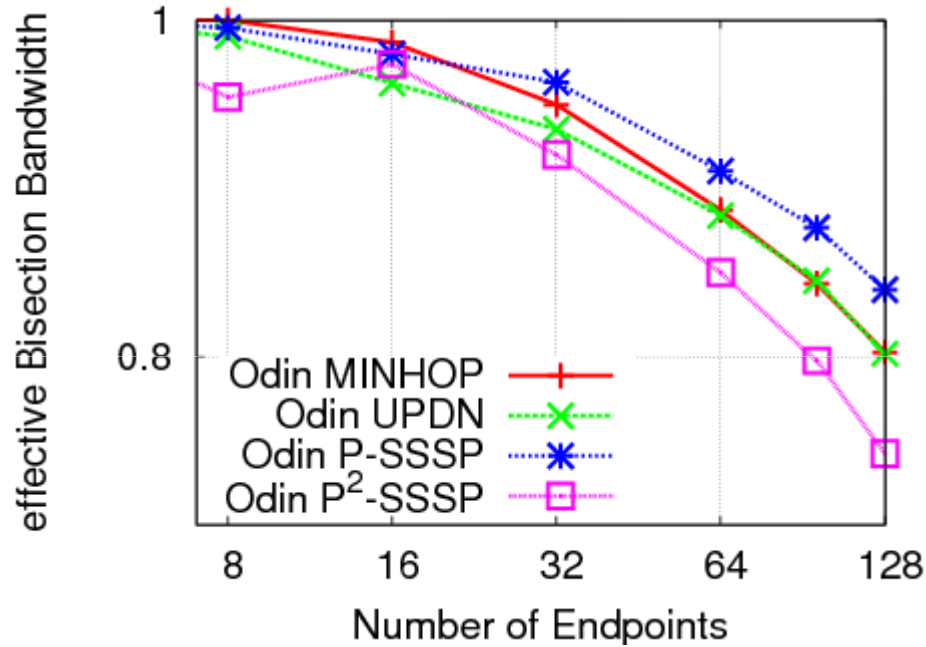

Simulation predicts 5% improvement

Benchmark
(Netgauge Pattern eBB)

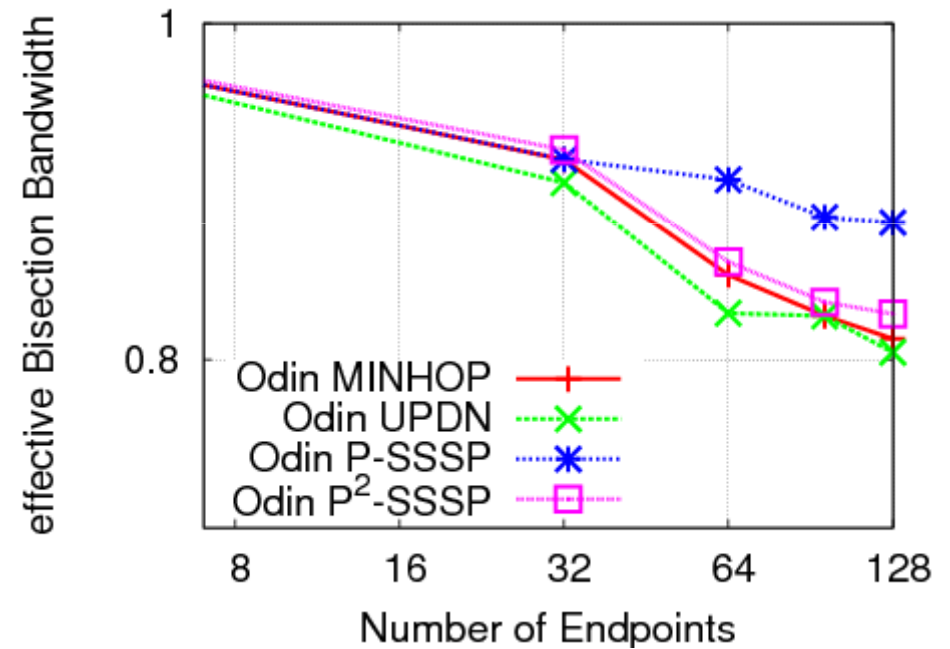

Benchmark shows 18% improvement!



Benchmark Results Deimos

Simulation

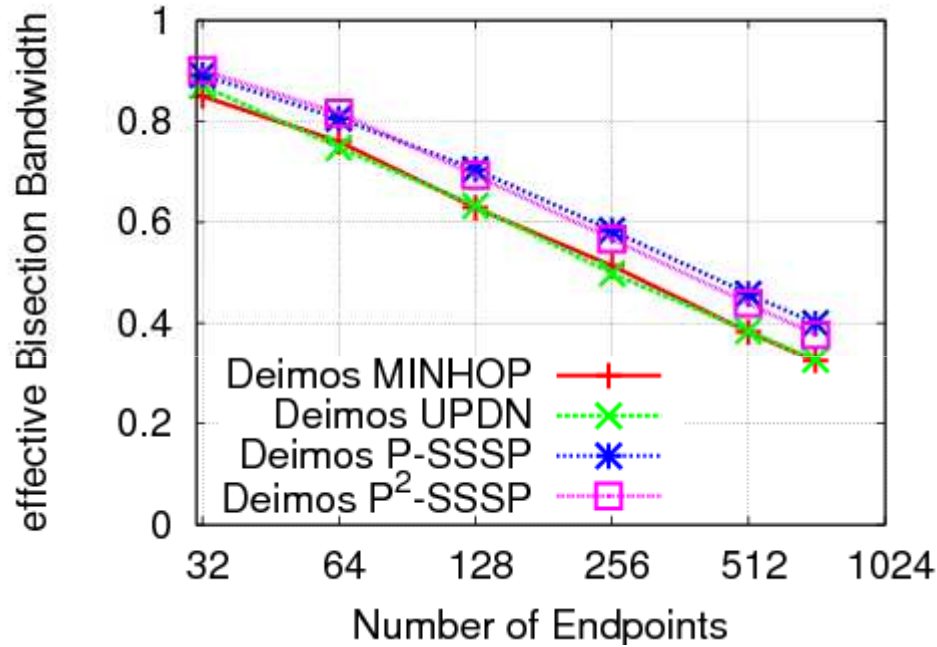

Simulation predicts 23% improvement

Benchmark
(Netgauge Pattern eBB)

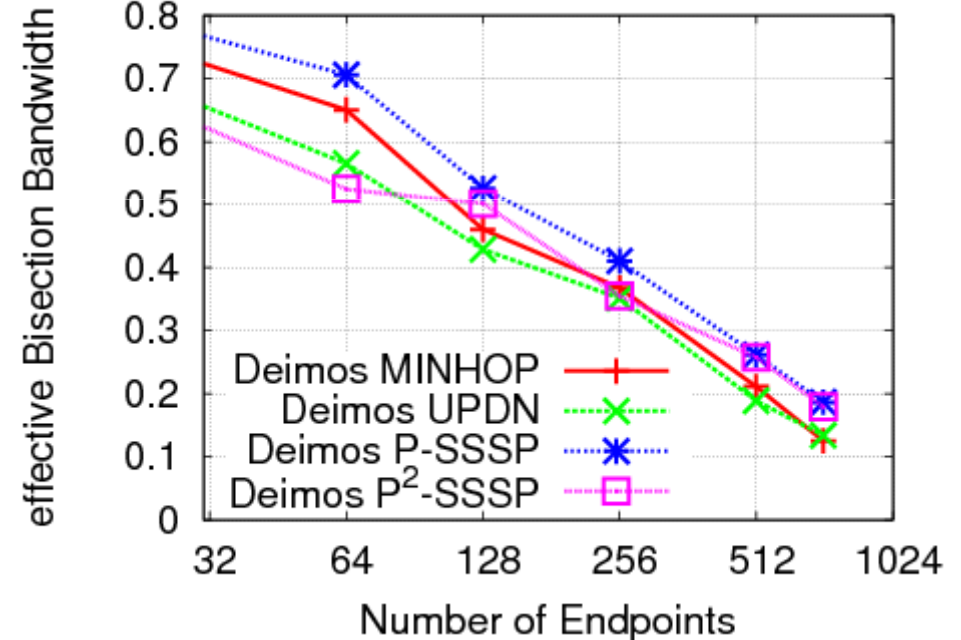

Benchmark shows 40% improvement!

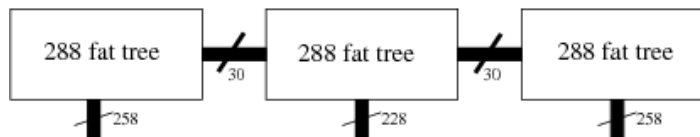

Summing up and Future Work!

- we proposed two new routing heuristics for deterministic oblivious routing (IB)
- simulation shows increase in effective bisection bandwidth over standard OpenSM routing
 - e.g., Odin 5%, Deimos 23%, Atlas 15%, Thunderbird 6%
- benchmarks show even higher improvements
 - Odin 18%, Deimos 40%
- Credit-loops remain, but solution is obvious (LASH-like VL principle)



Reproduce our Results!

- talk to us!

- play with our ORCS simulator
 - <http://www.unixer.de/ORCS>

- benchmark your cluster (and talk to us)
 - Netgauge pattern “ebb”
 - <http://www.unixer.de/research/netgauge>

- ask questions – now!



Backup Slides

Backup Slides



Credit Loops Continued ...

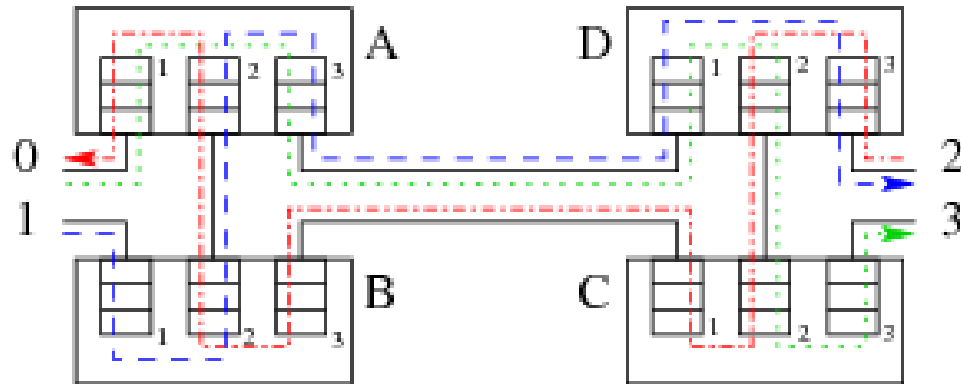

Source Network and Routes

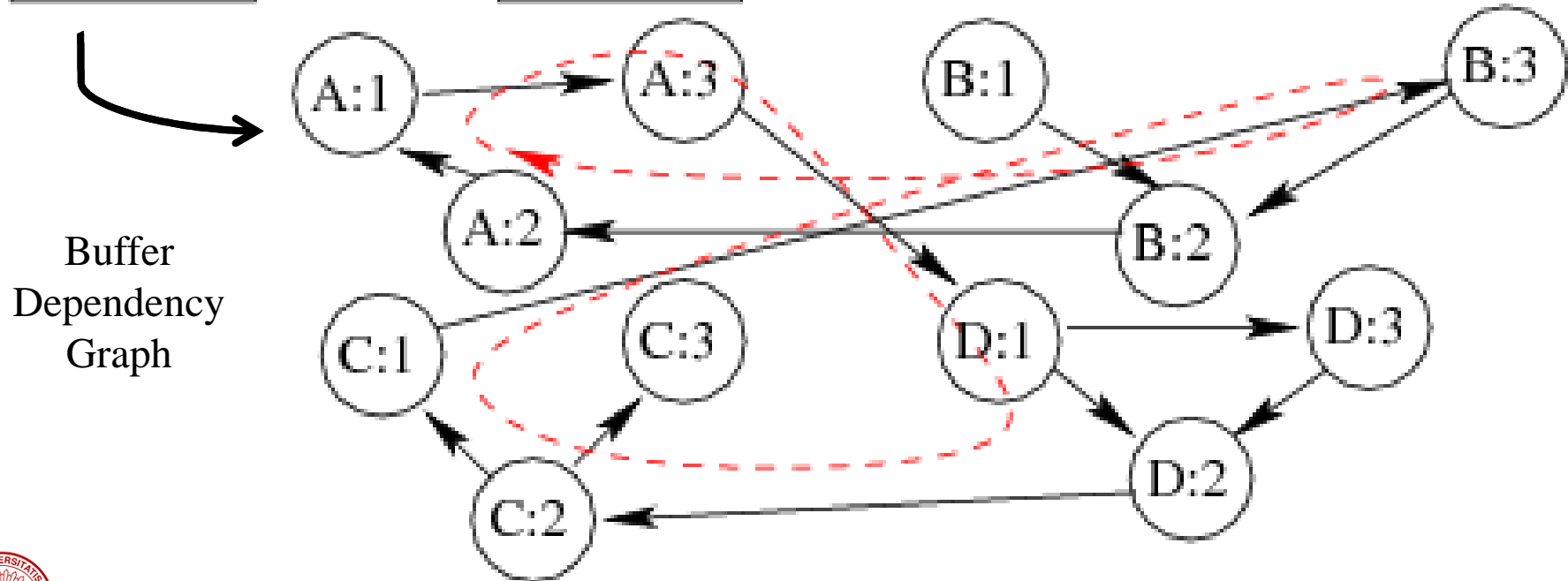

Buffer
Dependency
Graph



Lower $\pi(G,R)$ and lower bandwidth!?

□ Yes!

- $\pi(G,R)$ is just an upper bound
- example:

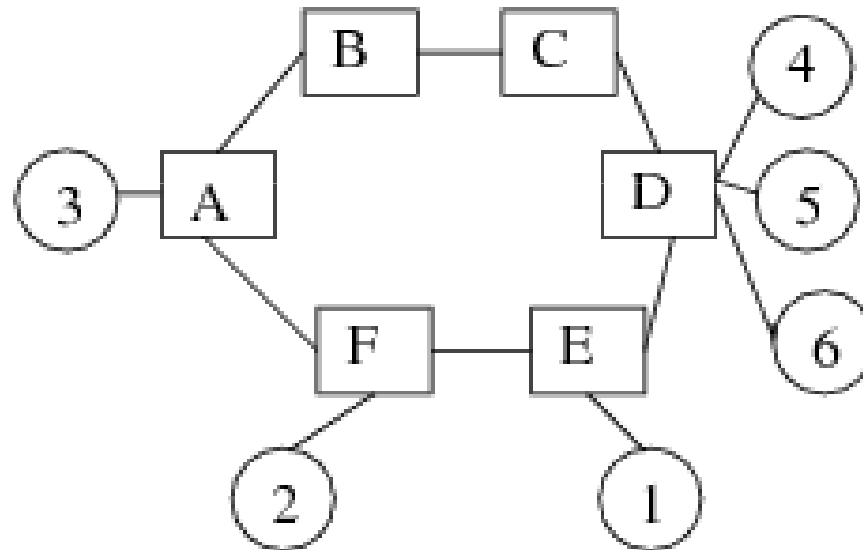

- no worries, I will not explain it here (refer to article for details)

